

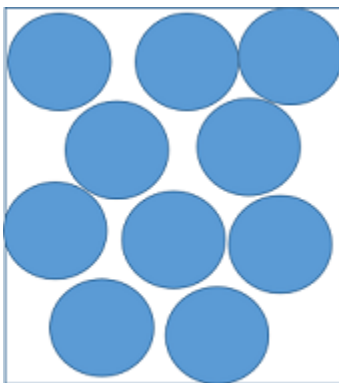

Practice Packet

Topic 5: Water & Ground

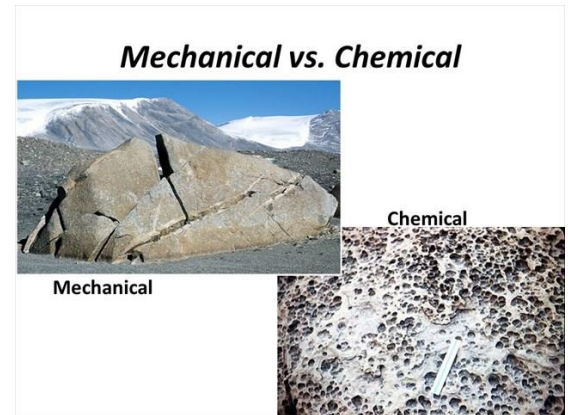
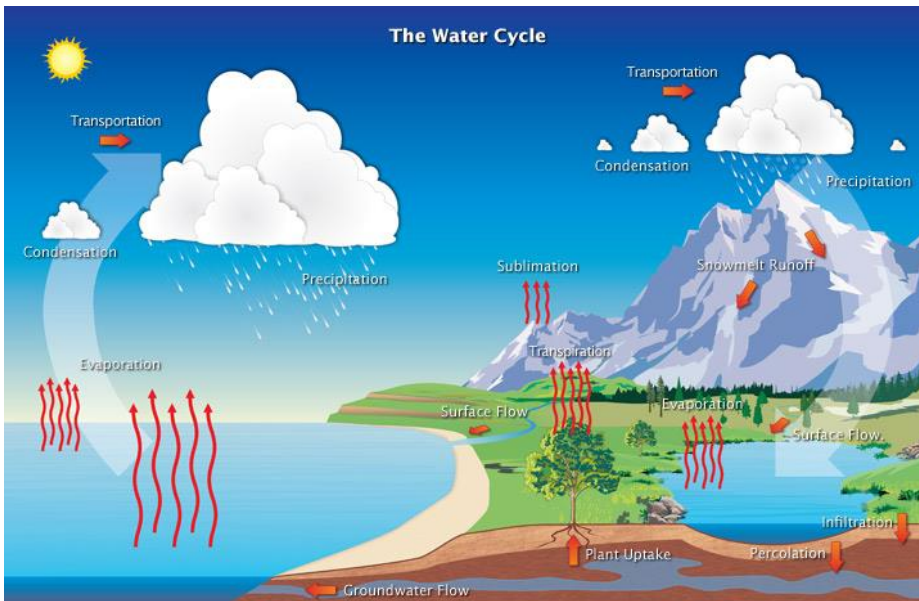

High porosity – large spaces

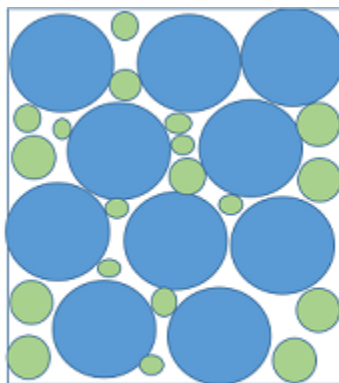

Low porosity – small spaces

Vocabulary: _____

Lesson 1: _____

Lesson 2: _____

Lesson 3: _____

Lesson 4: _____

Name: _____

PRACTICE PACKET: TOPIC 5 Surface Processes & Landscapes: Water & Ground

VOCABULARY

For each word, provide a short but specific definition from YOUR OWN BRAIN! No boring textbook definitions. Write something to help you remember the word. Explain the word as if you were explaining it to an elementary school student. Give an example if you can. Don't use the words given in your definition!

Water Cycle: _____

Evaporation: _____

Condensation: _____

Transpiration: _____

Precipitation: _____

Infiltration: _____

Runoff: _____

Water Retention: _____

Ground water discharge: _____

Zone of Aeration: _____

Zone of Saturation: _____

Water Table: _____

Saturated: _____

Porosity: _____

Permeable: _____

Impermeable: _____

Capillarity: _____

Weathering: _____

Chemical Weathering: _____

Physical Weathering: _____

Oxidation: _____

PRACTICE PACKET: TOPIC 5 Surface Processes & Landscapes: Water & Ground

Frost action: _____

Abrasion: _____

Exposure: _____

Soil: _____

Erosion: _____

Deposition: _____

Dynamic Equilibrium: _____

Lesson 1 - Water Cycle

Objective:

- I can label the water cycle
- I can state the energy needed to fuel the water cycle
- I can contrast the differences between runoff & infiltration
- I understand the water budget

Matching:

_____ 1. Condensation

A. water soaking into the ground

_____ 2. Evaporation

B. change in phase from liquid water to water vapor (gas)

_____ 3. Infiltration

C. movement of water along Earth's surface

_____ 4. Precipitation

D. change in phase from water vapor (gas) to liquid water

_____ 5. Runoff

E. rain, sleet, and hail are examples



_____ 6. Transpiration

F. water vapor enters the atmosphere from the leaves of plants

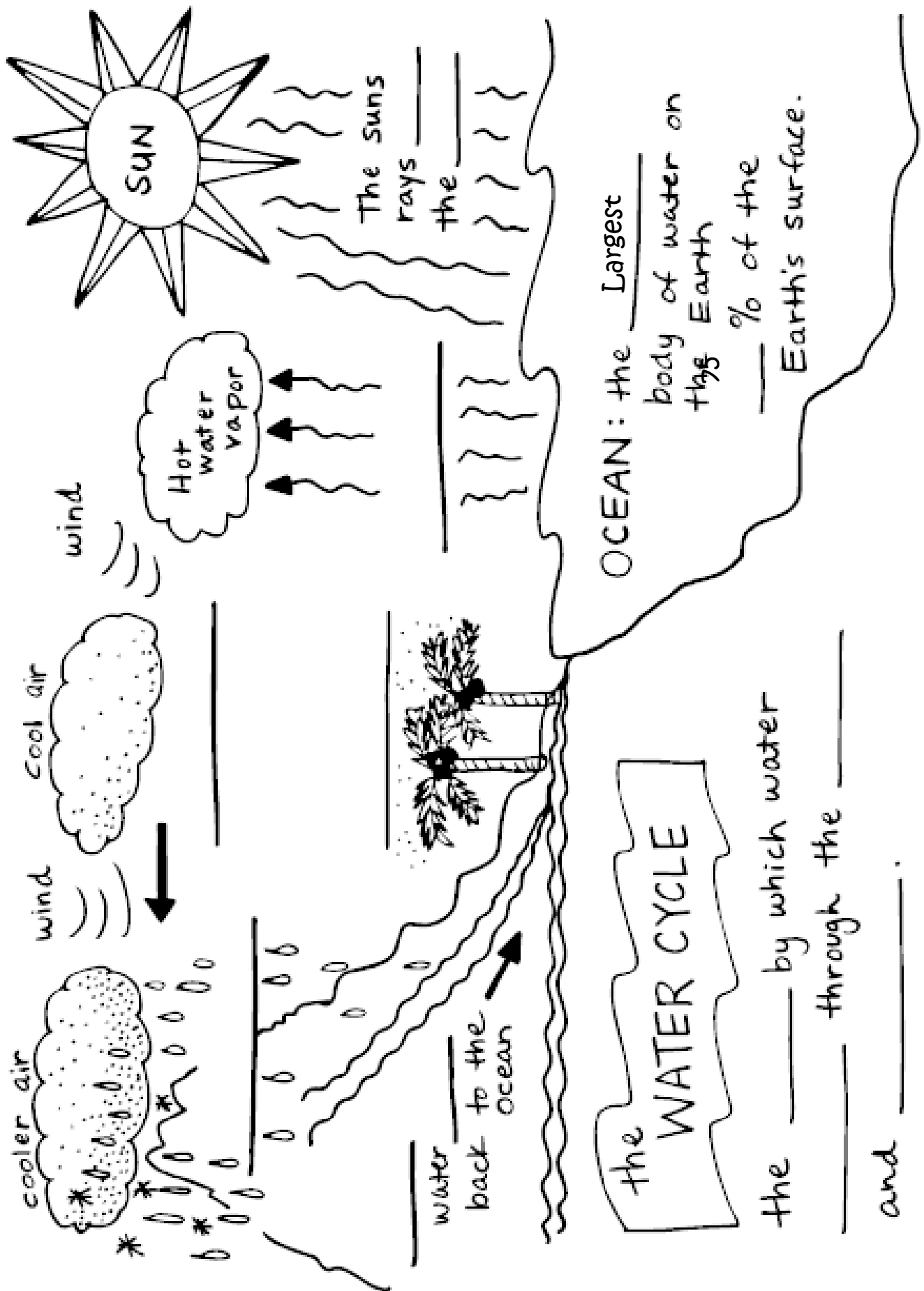
7. What drives the water cycle? _____

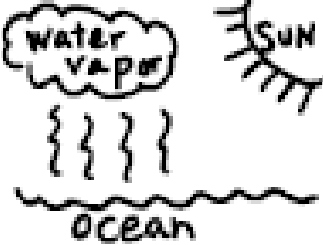

PRACTICE PACKET: TOPIC 5 Surface Processes & Landscapes: Water & Ground

Draw a Picture	Vocabulary Word	Definition
 <p style="text-align: center;">ocean</p>		
		<p>Water droplets fall from the atmosphere in the form of rain, snow, or hail</p>
	<p>Condensation</p>	
 <p style="text-align: center;">ocean</p>		
		<p>The passage of water vapor from plants to the atmosphere.</p>
 <p style="text-align: center;">water</p>		
	<p>Infiltration</p>	

PRACTICE PACKET: TOPIC 5 Surface Processes & Landscapes: Water & Ground

Regents Questions:

Base your answers to questions 1 through 4 on the model and data table shown to the right. A student constructed a model to demonstrate how water is recycled by natural processes on Earth. The model consisted of a clear plastic tent over a pan containing a bowl of water. The model was sealed so no water could enter or leave the tent. The data table shows the observations recorded when the model was placed in direct sunlight for 60 minutes.

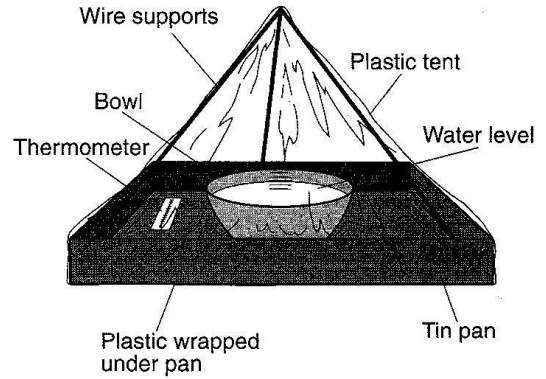

Data Table

Time (min)	Observations
0	Water level in bowl = 10 cm Inside walls of the plastic tent are dry. Inside air temperature = 20°C
30	Water level in bowl = 9.9 cm Small drops of water form on the inside walls of the tent. Inside air temperature = 23°C
60	Water level in bowl = 9.8 cm Large drops of water form on the inside walls of the tent. Inside air temperature = 26°C

1. Identify the process that caused the water level in the bowl to decrease.
2. How much heat energy, in Joules per gram, is released as water droplets are formed on the inside walls of the tent?

3. If the model is changed and the bowl of water is replaced with a green plant, by which process would the plant supply water vapor to the air inside the tent?

4. A student glues a Y-shaped piece of plastic, as shown to the right, near the top of the inside of the tent and repeats the demonstration. Drops of water are seen dripping from the bottom of the Y after 60 minutes. Which process of the water cycle is being represented by the dripping water?

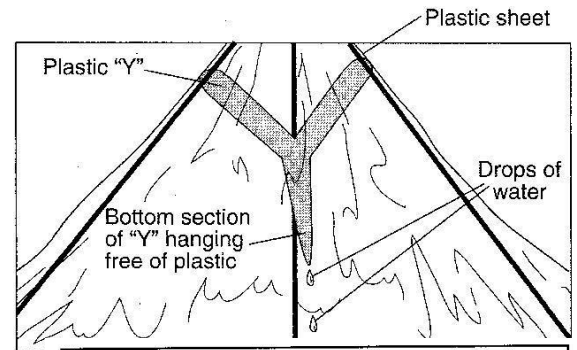

5. The letters A through D on the cross section to the right represent four of the processes that are part of the water cycle. Which table below correctly matches each letter with the process that it represents?

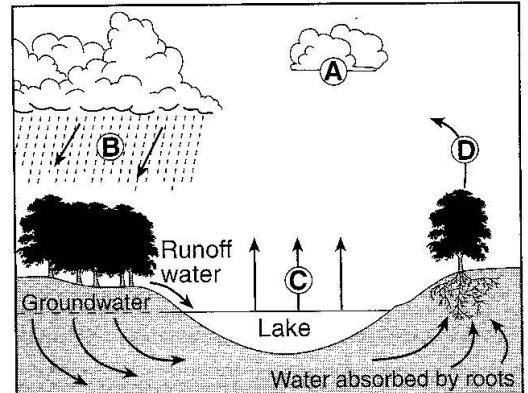

Letter	Process
A	condensation
B	precipitation
C	transpiration
D	evaporation

(1)

Letter	Process
A	transpiration
B	precipitation
C	evaporation
D	condensation

(3)

Letter	Process
A	evaporation
B	condensation
C	precipitation
D	transpiration

(2)

Letter	Process
A	condensation
B	precipitation
C	evaporation
D	transpiration

(4)

PRACTICE PACKET: TOPIC 5 Surface Processes & Landscapes: Water & Ground

- Calculate the total amount of water stored in the atmosphere, the oceans, and on the continents at any one time.
- Explain why the yearly total precipitation over the oceans is greater than the yearly total precipitation over the continents.

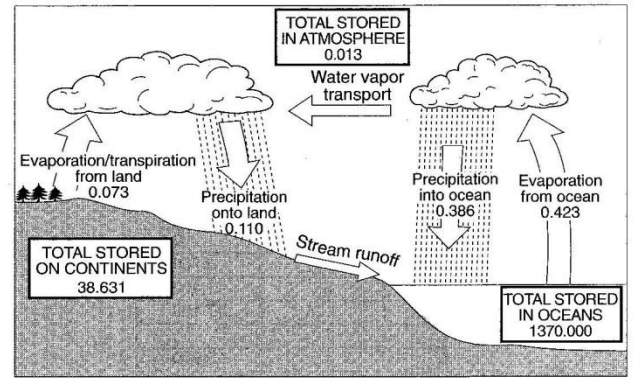

Base your answers to questions 8 through 10 on the water cycle diagram shown below. Some arrows are numbered 1 through 4 and represent various processes.

Hydrologic Cycle

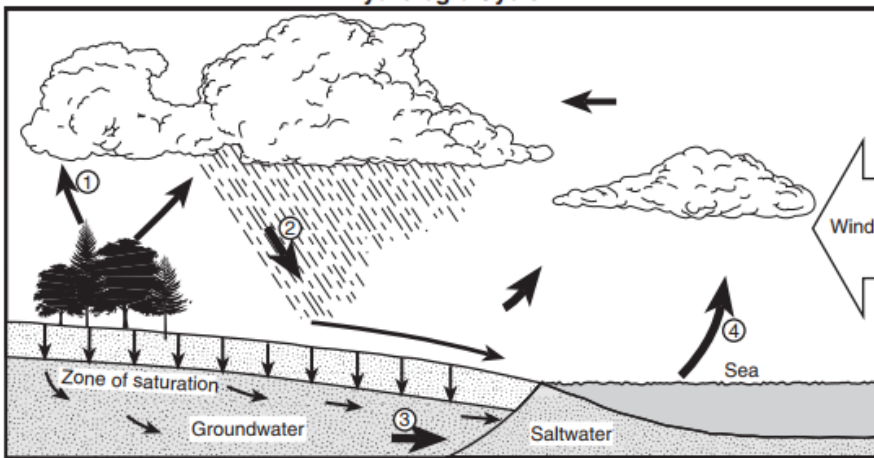

- Which numbered arrow best represents the process of transpiration?
 - 1
 - 2
 - 3
 - 4
- The clouds have formed primarily because moist air
 - rises, expands, and cools
 - sinks, compresses, and cools
 - rises, expands, and warms
 - sinks, compresses, and warms

- For infiltration to occur, the ground must be
 - permeable and saturated
 - permeable and not saturated
 - impermeable and saturated
 - impermeable and not saturated

ASSESS YOURSELF ON THIS LESSON: _____/10

If you missed more than 2, do the Additional Practice. If not, go on to the next hw video!!!

- The diagram below is a cross-sectional view of rain falling on a farm field and then moving to the water table. Which word best describes the movement of the rainwater through zone A?
 - runoff
 - infiltration
 - saturation
 - precipitation
- Which word best describes the movement of the rainwater through zone C?
 - runoff
 - infiltration
 - saturation
 - precipitation

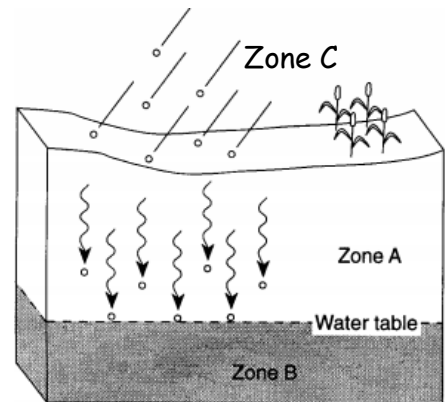

PRACTICE PACKET: TOPIC 5 Surface Processes & Landscapes: Water & Ground

Base your answers to questions 3 through 5 on the diagram below, which represents Earth's water cycle. The arrows represent some water cycle processes. Letter A indicates a surface location on Earth.

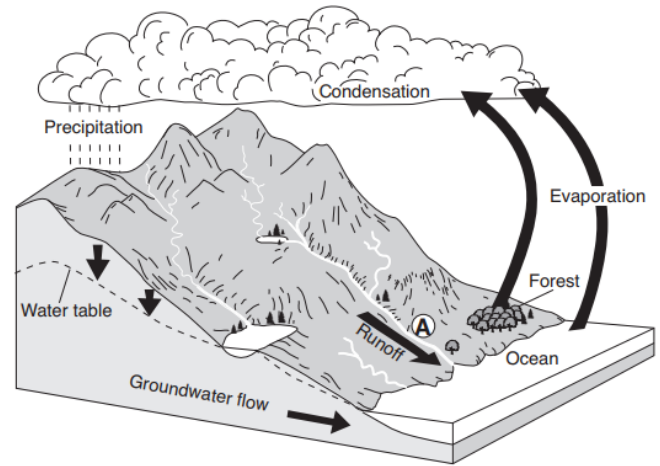

- Other than evaporation, which water cycle process transfers large amounts of water vapor into the atmosphere from the forest?
- Describe one surface condition change at location A that would decrease the rate of runoff.
- How many joules (J) of heat energy are released by each gram of water vapor that condenses to form cloud droplets?

ASSESS YOURSELF ON THIS ADDITIONAL PRACTICE: _____/5

If you missed more than 2 see me for extra help and/or re-watch the lesson video assignment.

Lesson 2 - Porosity Notes

Objective:

- I can divide the earth's surface into layers
- I can describe the factors that affect infiltration
- I can explain porosity
- I can describe permeability
- I can define capillarity
- I can describe factors that affect runoff

In order for water to infiltrate the soil, the soil must be porous. Simply stated, porosity is the amount of air space between the tiny pieces of sediment in the soil. If the ground does not have any "porosity", infiltration cannot occur. When the soil is permeable it means water can pass through the open air spaces. The speed at which water infiltrates depends on size of the particle, if they are sorted and how they are packed. This is called permeability rate. If the soil is impermeable, water will not be able to infiltrate.

When the ground is saturated, frozen or consists of solid rock material, it is considered impermeable and runoff increases. Runoff may also be accelerated if the surface has a steep slope or when rain comes down so fast the water does not have time to soak into the ground. Let's not forget the human factor. The building of cities, roads and parking lots has created large impermeable areas that have significantly altered the water cycle. A factor that may increase infiltration is the amount of vegetation. Vegetation tends to slow down runoff, giving water time to soak into the ground.

PRACTICE PACKET: TOPIC 5 Surface Processes & Landscapes: Water & Ground

Within the soil, the area at the surface where water can pass through is called the zone of aeration. Where the soil that is filled with water is called the zone of saturation. At the top of the zone of saturation, where the water is at its highest, is called the water table. The water table generally will move higher toward the surface in spring because rain water replenishes the water, however during a hot summer it will begin to move downward. If the water moves down through the soil to the water table, how do plants get the water they need to flourish? Capillarity within the soil is the upward movement of water. The smaller the pore space the greater the rate of capillarity.

1. What is porosity? _____
How does it affect infiltration? _____
2. List the **four** factors that will increase permeability rate. _____,
_____, _____, and

3. What **five** factors increase runoff? _____

4. Where does the water go in the city when it rains? _____

5. How does vegetation help water soak into the ground? _____

6. How does slope affect runoff and infiltration rate? _____

7. How does particle size affect capillarity? _____

Matching: Place the letter of the statement that best describes the process listed.

- | | |
|-----------------------------|---|
| _____ 1. Permeability rate | A. The amount of "air" space within the soil |
| _____ 2. Porosity | B. Located at the top of the zone of saturation |
| _____ 3. Capillarity | C. How fast water infiltrates into the soil |
| _____ 4. Water table | D. The area within the soil that is not filled with water |
| _____ 5. Zone of Aeration | E. When water is drawn upward through the soil |
| _____ 6. Zone of Saturation | F. The area within the soil that is filled with water |

PRACTICE PACKET: TOPIC 5 Surface Processes & Landscapes: Water & Ground

Using the diagram, label & describe each of the following terms:

a) Zone of Aeration:

b) Zone of Saturation:

c) Water Table:

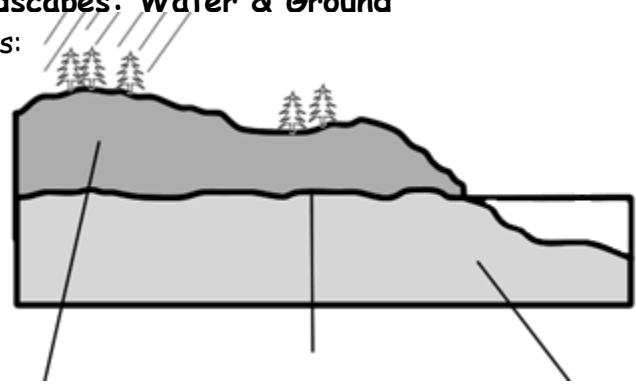

Porosity, Permeability and Capillarity

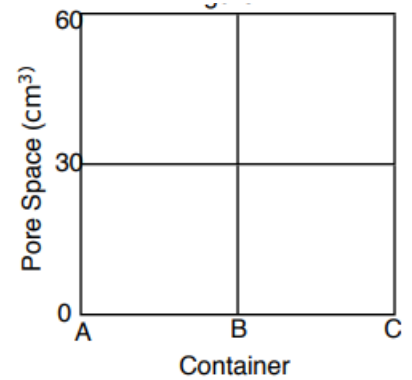
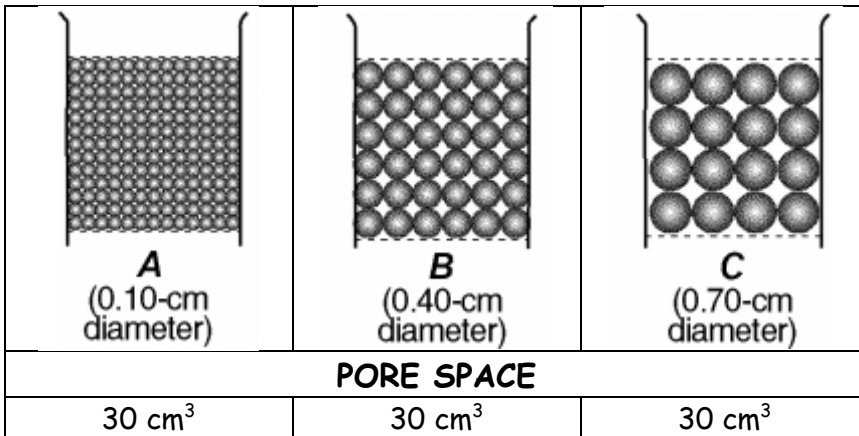

1. What is porosity?
2. How does the porosity of the three containers compare?
3. State the relationship between particle size and porosity & GRAPH it above.

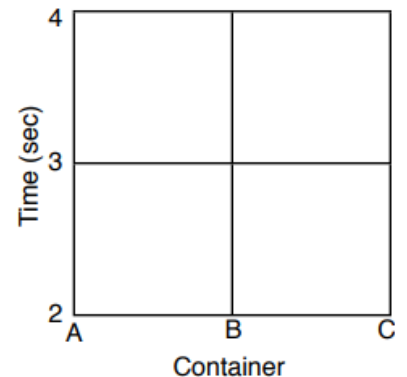
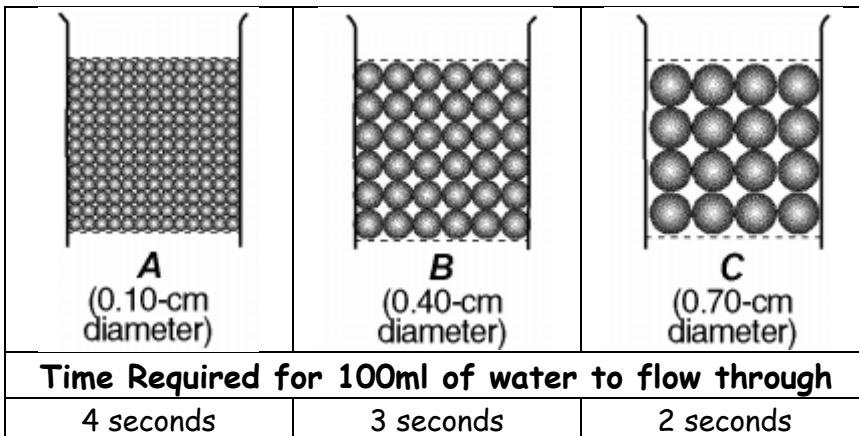

4. What is permeability?
5. How does the permeability of the three containers compare?
6. State the relationship between particle size and permeability & GRAPH it above.

PRACTICE PACKET: TOPIC 5 Surface Processes & Landscapes: Water & Ground

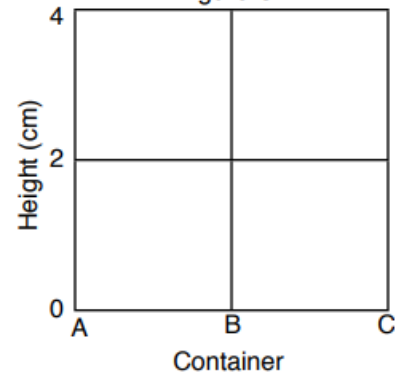
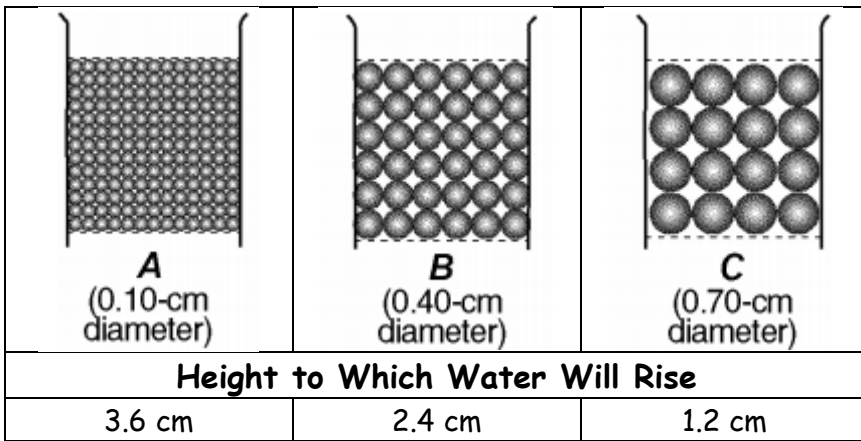

7. What is capillarity?
8. How does the capillarity of the three containers compare?
9. State the relationship between particle size and capillarity & GRAPH it above.
10. Which container would RETAIN the most water & why?

Regents Questions:

1. Which earth material covering the surface of a landfill would permit the least amount of rainwater to infiltrate the surface?
 - a. silt
 - b. sand
 - c. clay
 - d. pebbles
2. Which graph best represents the relationship between soil permeability rate and infiltration when all other conditions are the same?

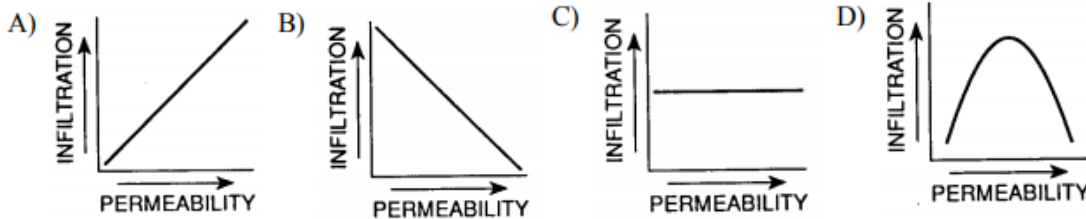

3. Which set of surface soil conditions on a hillside would result in the most infiltration of rainfall?
 - a. gentle slope, saturated soil, no vegetation
 - b. gentle slope, unsaturated soil, vegetation
 - c. steep slope, saturated soil, vegetation
 - d. steep slope, unsaturated soil, no vegetation
4. Flash flooding often occurs in city areas because
 - a. runoff decreases during precipitation
 - b. ground water storage is usually very large
 - c. roads, pavements, and buildings reduce the infiltration of water into the ground
 - d. the heat generated by city areas decreases actual evapotranspiration

PRACTICE PACKET: TOPIC 5 Surface Processes & Landscapes: Water & Ground

Base your answers to questions 5 through 10 on the diagram below and on your knowledge of Earth science. The diagram represents setups of laboratory equipment, labeled A, B, C, and D. This equipment was used to test the infiltration rate and water retention of four different particle sizes. Each column was filled to the same level with uniform-sized dry, spherical particles. Water was poured into each column until the water level rose to the top of the particles. Then, the clamp was opened to allow the water to drain into the beaker beneath each column.

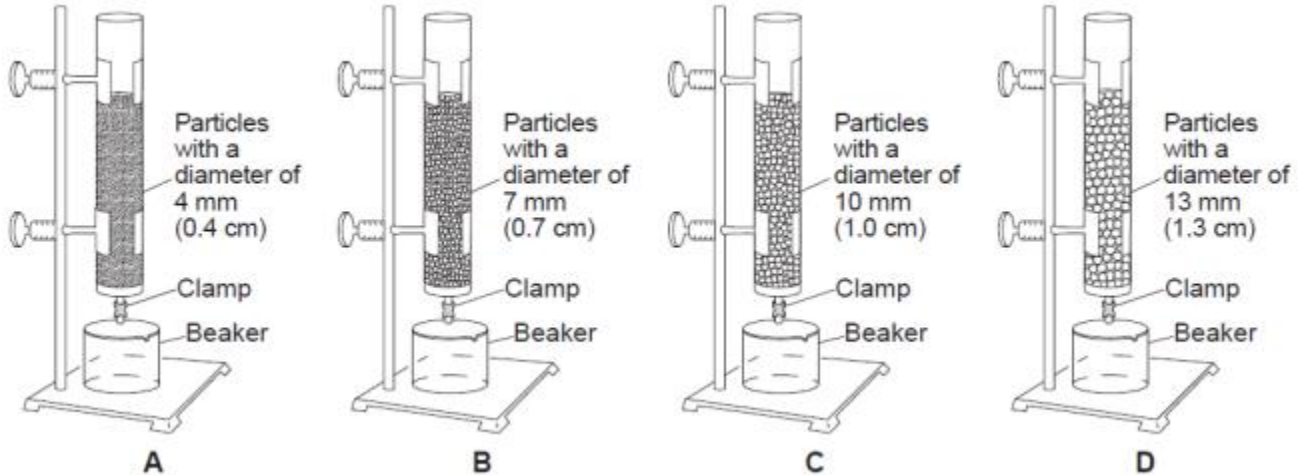

5. All of the particles in these four columns are classified as
 - a. clay
 - b. silt
 - c. sand
 - d. pebbles
6. Which container would show the most capillarity?
 - a. A
 - b. B
 - c. C
 - d. D
7. Which graph best shows the rate of infiltration of water through the particles in these four columns?

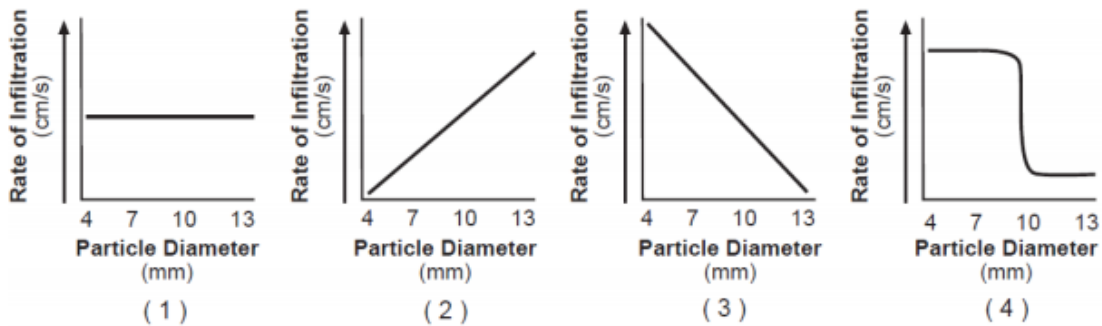

8. Which column of particles retained the most water after the clamps were opened and the water was drained into the beakers?
 - a. A
 - b. B
 - c. C
 - d. D
9. All four tubes of beads had approximately the same
 - a. Porosity
 - b. water retention
 - c. permeability time
 - d. capillarity
10. Water will be able to infiltrate each of these sediment samples if the sediment is
 - a. saturated and impermeable
 - b. unsaturated and impermeable
 - c. saturated and permeable
 - d. unsaturated and permeable

PRACTICE PACKET: TOPIC 5 Surface Processes & Landscapes: Water & Ground

11. Sediment samples A through D below have the same volume and packing, but contain different percentages of various particle sizes.

Sample A: 75% clay and 25% silt

Sample B: 25% clay and 75% sand

Sample C: 50% pebbles and 50% sand

Sample D: 50% pebbles and 50% cobbles

Which sample most likely has the greatest permeability?

- a. A b. B c. C d. D

ASSESS YOURSELF ON THIS LESSON: _____/11

If you missed more than 3, do the Additional Practice. If not, go on to the next hw video!!!

- Which surface soil conditions allow the most infiltration of rainwater?
 - steep slope and permeable soil
 - gentle slope and permeable soil
 - steep slope and impermeable soil
 - gentle slope and impermeable soil

- Through which of the following loose soil materials does water infiltrate fastest?
 - silt
 - sand
 - clay
 - pebbles

- The diagram below represents three identical beakers filled to the same level with spherical beads.

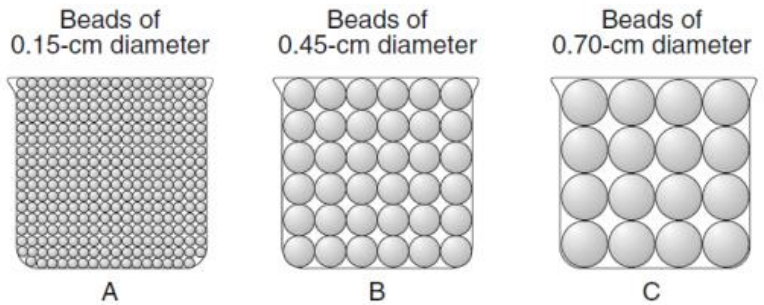

If the packing of the beads within each beaker is the same, which graph best represents the porosity within each beaker?

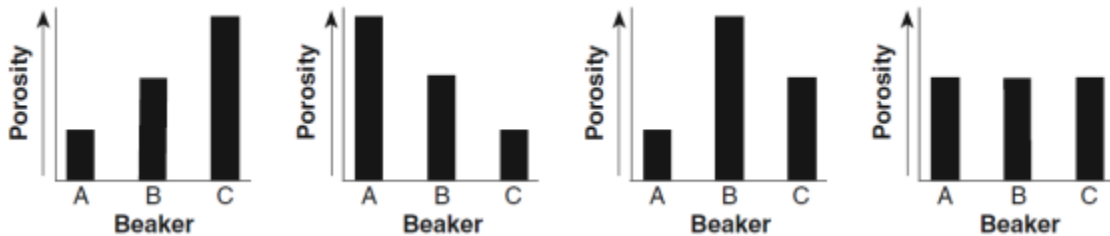

- Which graph shows the general relationship between soil particle size and the capillarity of the soil?

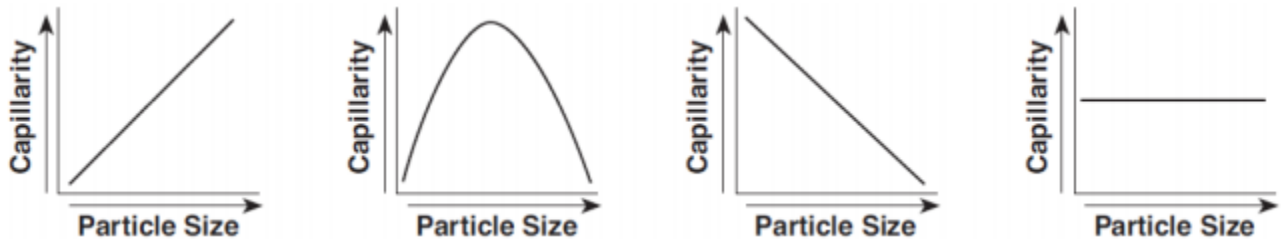

- Most infiltration of precipitation will occur when the Earth's soil is
 - unsaturated and impermeable
 - saturated and impermeable
 - unsaturated and permeable
 - saturated and permeable

ASSESS YOURSELF ON THIS ADDITIONAL PRACTICE: _____/5

If you missed more than 2 you should see me for extra help and/or re-watch the lesson video assignment.

PRACTICE PACKET: TOPIC 5 Surface Processes & Landscapes: Water & Ground

Lesson 3 - Weathering

Objective:

- I can define weathering
- I can differentiate between chemical & physical weathering
- I can state examples of chemical weathering
- I can state examples of physical weathering
- I can describe the factors that affect the rate & type of weathering
- I can explain soil formation

Weathering is the breakdown of rock material. The first type we will investigate is physical (mechanical) weathering. During physical weathering the rocks are simply broken up into fragments. It does not change the composition of the rock but it does create more surface area. The dominant climate condition for physical weathering is cold and moist. Chemical weathering occurs on the surface of rocks and changes the composition of the material. This causes the rocks to weaken and makes it easier for them to break apart. Chemical weathering dominates in warm moist climates and occurs on the surface of the rocks. Usually both types of weathering work together but the dominant type depends on the climate of the area.

1. What is weathering? _____
2. What is another name for physical weathering? _____
3. What does physical weathering do? _____
4. Does physical weathering change the composition of the rock? _____
5. What does physical weathering create? _____
6. What are the dominant climate conditions for physical weathering? _____
7. What does chemical weathering do? _____
8. What does chemical weathering cause? _____
9. Where on the rock does chemical weathering occur? _____
10. What are the dominant climate conditions for chemical weathering? _____
11. Explain how physical weathering helps chemical weathering occur. ** Use a complete sentence.**

12. Explain how chemical weathering helps physical weathering occur. ** Use a complete sentence.

13. What climate factor aids in both chemical and physical weathering? _____
14. What are the four basic factors that the rate of weathering is dependent on? (use notes)

PRACTICE PACKET: TOPIC 5 Surface Processes & Landscapes: Water & Ground

Complete the tables with the information pertaining to the images.

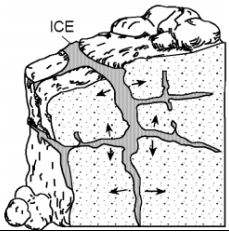
	Name	Type of Weathering	Description
	Ice Wedging or Frost Action		

	Name	Type of Weathering	Description
	Sandblasting		

	Name	Type of Weathering	Description
	Carbonation of Limestone		carbonic <u>acid</u> in rain causes minerals to dissolve ex. marble gravestones

	Name	Type of Weathering	Description
	Stream Abrasion		

	Name	Type of Weathering	Description
	Plant root growth		

	Name	Type of Weathering	Description
	Oxidation		

Regents Questions:

1. Soil was formed mainly by
 - a. compaction and cementing
 - b. weathering and biological activity
 - c. faulting and tilting of rock strata
 - d. mass movement and deposition of particles

PRACTICE PACKET: TOPIC 5 Surface Processes & Landscapes: Water & Ground

2. The block diagram below represents a landscape where caverns and sinkholes have gradually developed over a long period of time.

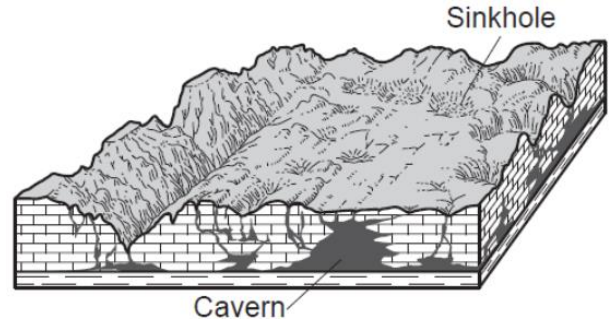

- Why did these caverns and sinkholes form?
- The bedrock chemically reacted with acidic groundwater.
 - This type of bedrock contained large amounts of oxygen and silicon.
 - Glacial deposits altered the shape of the bedrock.
 - Crustal uplift formed gaps in the bedrock.

3. Which type of weathering was primarily responsible for the development of these caves?

- physical weathering of sandstone
- chemical weathering of sandstone
- physical weathering of limestone
- chemical weathering of limestone

4. Which rock went through the most abrasion?

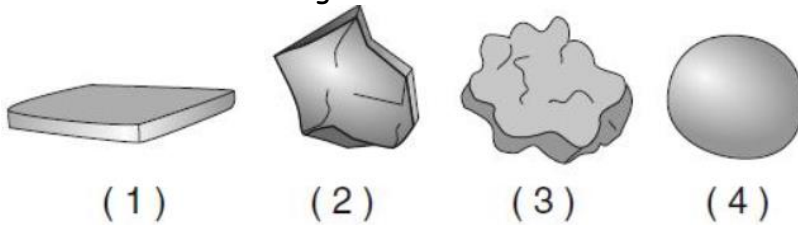

5. Which rock weathers most rapidly when exposed to acid rain?

- quartzite
- granite
- basalt
- limestone

6. Which mineral would most likely become rounded at the fastest rate when tumbled along a stream bottom?

- garnet
- pyroxene
- plagioclase feldspar
- selenite gypsum

7. Which rock layer is the most resistant (_____) to weathering?

- 1
- 2)4
- 3) 2
- 4) 3

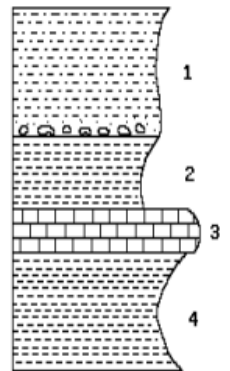

8. Which is the best example of physical weathering?

- the cracking of rock caused by the freezing and thawing of water
- the transportation of sediment in a stream
- the reaction of limestone with acid rainwater
- the formation of a sandbar along the side of a stream

9. A large rock is broken into several smaller pieces. Compared to the rate of weathering of the large rock, the rate of weathering of the smaller pieces is

- the same
- less
- greater

10. Which change in the climate of New York State would most likely cause the greatest increase in chemical weathering of local bedrock?

- lower humidity in winter
- lower temperature in winter
- greater precipitation in summer
- higher atmospheric pressure in summer

PRACTICE PACKET: TOPIC 5 Surface Processes & Landscapes: Water & Ground

Base your answers to questions 11 through 13 on the diagram below, which represents the dominant type of weathering for various climatic conditions.

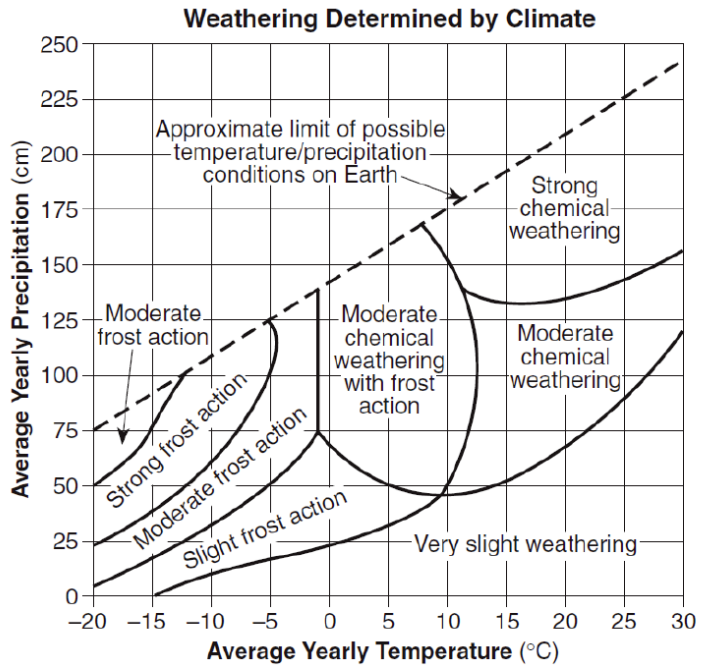

11. Which climate conditions would produce very slight weathering?
- a mean annual temperature of 25 °C & a mean annual precipitation of 100 cm
 - a mean annual temperature of 15°C and a mean annual precipitation of 25 cm
 - a mean annual temperature of 5 °C and a mean annual precipitation of 50 cm
 - a mean annual temperature of -5°C and a mean annual precipitation of 50 cm

12. What type of weathering dominates when the mean annual temperature of -5 °C and a mean annual precipitation of 60 mm?

- moderate frost action
- moderate chemical weathering
- slight frost action
- very slight weathering

13. Why is no frost action shown for locations with a mean annual temperature greater than 13 °C?

- Very little freezing takes place at these locations.
- Large amounts of evaporation take place at these locations.
- Very little precipitation falls at these locations.
- Large amounts of precipitation fall at these locations.

Base your answers to questions 14 to 17 on the experiment described. Each rock sample was placed in a separate beaker containing 500 milliliters of a dilute acid for 10 minutes. Bubbling was observed in some of the beakers. The data table below shows the mass of each sample, in grams, before placement in the acid and after removal from the acid.

Data Table

Rock	Mass Before (g)	Mass After (g)
limestone	19.72	19.64
granite	20.77	20.77
gneiss	26.83	26.83
marble	20.81	20.73

14. Which Earth process is being modeled in this experiment?

- physical weathering in the hydrosphere
- physical weathering in the mesosphere
- chemical weathering in the hydrosphere
- chemical weathering in the mesosphere

15. Which table correctly shows the classification of the rock samples based on the amount of weathering during this experiment?

Group A	Group B
limestone marble	granite gneiss

Group A	Group B
limestone	granite marble gneiss

Group A	Group B
limestone granite gneiss	marble

Group A	Group B
limestone granite	gneiss marble

16. Approximately what percentage of the marble sample remained after the experiment?

- 0.4%
- 8.0%
- 20.7%
- 99.6%

PRACTICE PACKET: TOPIC 5 Surface Processes & Landscapes: Water & Ground

17. Which property of the gneiss sample prevented it from weathering?

- a. crystalline texture b. mineral composition c. density d. cleavage

ASSESS YOURSELF ON THIS LESSON: _____/17

If you missed more than 4, do the Additional Practice. If not, go on to the next hw video!!!

1. Which two rock units appear to be most resistant to weathering and erosion?

- a. Lockport dolostone and Whirlpool sandstone
 b. Rochester shale and Albion sandstone and shale
 c. Clinton limestone and shale and Queenston shale
 d. Thorold sandstone and Queenston shale

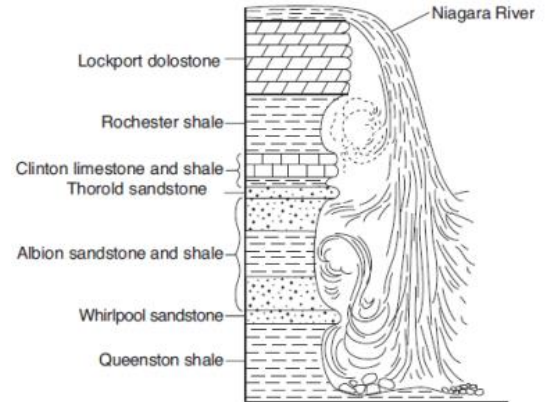

2. Equal masses of two identical rock samples. Sample A is one large block, while sample B was cut into four smaller blocks of equal size.

If subjected to the same environmental conditions, sample B will weather more quickly than sample A. The best explanation for this is that the



Sample A

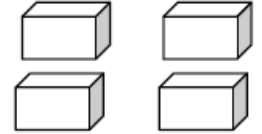

Sample B

- a. volume of Sample B is greater than that of Sample A
 b. surface area of Sample B is greater than that of Sample A
 c. density of Sample A is greater than that of Sample B
 d. hardness of Sample A is greater than that of Sample B

3. Landscapes will undergo the most chemical weathering if the climate is

- a. cool and dry b. cool and wet c. warm and dry d. warm and wet

4. Which factor has the greatest influence on the weathering rate of Earth's surface bedrock?

- a. local air pressure c. age of the bedrock
 b. angle of insolation d. regional climate

5. Which activity demonstrates chemical weathering?

- a. freezing of water in the cracks of a sandstone sidewalk
 b. abrasion of a streambed by tumbling rocks
 c. grinding of talc into a powder
 d. dissolving of limestone by acid rain

6. What is the main factor that causes the bedrock to weather at different rates?

- a. elevation above sea level c. age of rock layers
 b. mineral composition d. environment of formation

ASSESS YOURSELF ON THIS ADDITIONAL PRACTICE: _____/6

If you missed more than 2 you should see me for extra help and/or re-watch the lesson video assignment.

PRACTICE PACKET: TOPIC 5 Surface Processes & Landscapes: Water & Ground

Lesson 4 - Erosion & Deposition

Objective:

- I can define erosion
- I can name the number one force & number one agent of erosion
- I can define deposition & describe factors causing it
- I can describe how dynamic equilibrium is reached

THINKING CRITICALLY

Doomed Dunes?

Coasts are very dynamic environments. The changing tides, wind erosion, storms, and human traffic are some of the things that work to shape the coasts. Beach dunes are extremely sensitive to erosion from wind and human activity. Strong winds blowing from the ocean to the coast cause the dunes to migrate inland. People traveling over the dunes on foot and by vehicle stir up the sand and make it easier for the wind to transport it. If left unprotected, the dunes would surely be destroyed.

Many different plans for protecting dunes have been proposed and put into practice. Communities often prohibit people from walking, playing, or driving on beach dunes.

Another protection plan in use today is aimed at preventing wind erosion of the dunes. Some beach communities have begun planting grasses and burying old Christmas trees in front of dunes. The grasses and trees are set parallel to the dunes to form a protective wall between the dunes and the ocean.

Your Turn to Think

1. Why are dunes important?
2. Dunes are also eroded by the ocean during storms. How do grasses and old Christmas trees protect the dunes during storms?
3. Beaches are areas of limited sand supply. If the wind is causing the sand to migrate toward the land, how does a beach keep from losing all of its sand?
4. Which type of barrier, grasses or old Christmas trees, is better suited for the beach environment? Explain your answer.

Practice Questions:

1. What is erosion?

PRACTICE PACKET: TOPIC 5 Surface Processes & Landscapes: Water & Ground

2. Number 1 **agent** of erosion is _____ Number 1 **force** of erosion is _____
3. What is deposition?
4. What **five** factors affect the rate of deposition? _____,
_____, _____,
_____, & _____
5. _____ shape & _____ density of a particle would usually result in the **longest** settling time.
6. Is it possible to have erosion without deposition? Explain your answer.
7. What does dynamic equilibrium mean?



Circle the correct choice that describes how the factors affect erosion and deposition.

8. The faster the velocity of the medium the [more or less] sediment it can carry.
9. As the velocity of the medium slows down [more or less] sediment is deposited.
10. The larger the particle size the [easier or more difficult] it is moved.
11. The larger the particle size the [faster or slower] it is deposited.
12. The rounder the shape the [easier or more difficult] it is moved.
13. The rounder the shape the [faster or slower] it is deposited.
14. The more dense the particle size the [easier or more difficult] it is moved.
15. The more dense the particle size the [faster or slower] it is deposited.

PRACTICE PACKET: TOPIC 5 Surface Processes & Landscapes: Water & Ground

Base your answers to questions 16 through 21 on the diagrams below and descriptions of the two laboratory activities below. The particles used in these activities are described below.

Particles Used in Activities

Combination A		
Particle	Diameter	Density
●	15 mm Al (aluminum)	2.7 g/cm ³
●	10 mm Al (aluminum)	2.7 g/cm ³
●	5 mm Al (aluminum)	2.7 g/cm ³

Combination B		
Particle	Diameter	Density
Ⓐ	15 mm Al (aluminum)	2.7 g/cm ³
Ⓕ	15 mm Fe (iron)	7.9 g/cm ³
Ⓟ	15 mm Pb (lead)	11.4 g/cm ³

Activity 1

Three different particles of different sizes were released in a plastic tube filled with water. The length of time each particle took to drop from point A to point B is shown in data table 1.

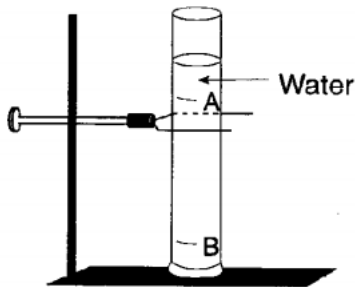

Data Table 1

Particle Size	Time of Settling
15 mm Al	3.2 sec
10 mm Al	5.4 sec
5 mm Al	7.2 sec

Using the relative sizes in the chart above, draw in a diagram to illustrate where each of the spheres would appear.



Activity 2

Different combinations of particles were placed in a tube filled with a thick liquid and allowed to fall to the bottom. The tube was then stoppered and quickly turned upside down, allowing the particles to settle. The different combinations of particles are shown in data table 2. The diagram of the partial sorting in data table 2 has been omitted intentionally.

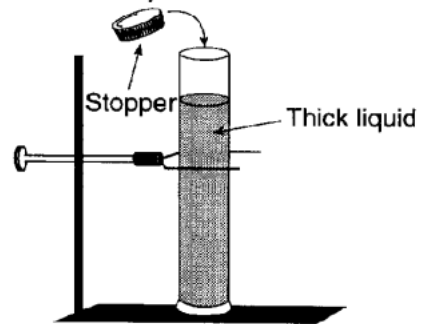

Using the labeled spheres in the chart above, draw in a diagram to illustrate where each of the spheres would appear.



PRACTICE PACKET: TOPIC 5 Surface Processes & Landscapes: Water & Ground

16. The diagrams below represent where each of the spheres would most likely be found once they settled to the bottom of the tube. In **Activity 1**, when the tube is turned upside down, the aluminum particles, labeled "Combination A," are allowed to settle. Which diagram below represents the sorting that is most likely to occur?

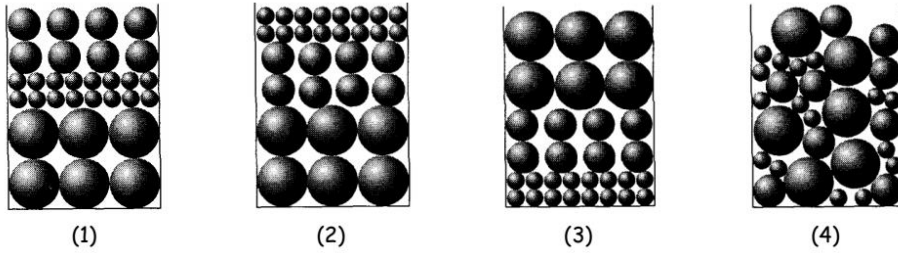

17. Explain your reasoning. _____

18. In **Activity 2**, when the tube is turned upside down, the particles of three different metals, labeled "Combination B," are allowed to settle. Which diagram below represents the sorting that is most likely to occur?

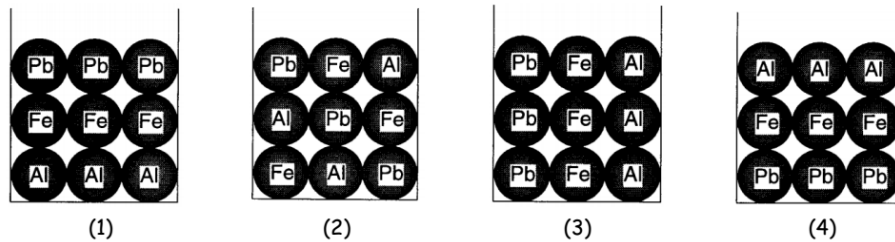

19. Explain your reasoning. _____

20. A third activity, similar in setup to Activity 1 was done using flat, oval, and round aluminum particles with identical masses. Which table shows the most likely results of this third activity?

Particle Shape	Settling Time
Round	3.2 sec
Oval	5.1 sec
Flat	6.7 sec

(1)

Particle Shape	Settling Time
Round	5.1 sec
Oval	3.2 sec
Flat	6.7 sec

(2)

Particle Shape	Settling Time
Round	5.1 sec
Oval	5.1 sec
Flat	5.1 sec

(3)

Particle Shape	Settling Time
Round	6.7 sec
Oval	5.1 sec
Flat	3.2 sec

(4)

21. Explain your reasoning. _____

22. **REVIEW:** State how each of the following factors affect erosion and deposition.

	Erosion	Deposition
Velocity of medium	_____ speed = more	_____ speed = more
Shape	Rounder = _____	Flatter = _____
Density	Higher density = _____	Higher density = _____
Size	Bigger = _____	Bigger = _____

PRACTICE PACKET: TOPIC 5 Surface Processes & Landscapes: Water & Ground

Directions: For each of the situations below, state whether it describes Erosion, Weathering, or Deposition or possibly more than one.

23. Over the course of two years, the top layer of soil at a Michigan farm is blown away. _____
24. A very large storm occurs along the coast. The powerful waves wash away sand and move some larger rocks on the shore. _____
25. Rainfall collects in a crack in a rock. When the temperature drops, this water freezes and expands. This causes the crack to become slightly larger. _____
26. This rock is at the top of a cliff. After several years, the crack is large enough that a piece breaks off and tumbles to the bottom. _____
27. A tree in your front yard spreads its roots beneath a sidewalk, pushing the sidewalk up and causing it to crack. As the tree grows, these cracks are expanded as the roots grow into and between them. _____
28. A glacier scrapes pieces of rock from underneath it and carries these pieces down the side of a mountain and into the valley. _____
29. A river flowing through soft rock dissolves some of the rock and carries this material downstream. _____
30. As a fire rages through a forest, a large boulder is heated quickly. This rapid change in temperature causes the outer layer of the boulder to crack. _____

Regents Questions:

Base your answers to questions 1 through 3 on the cross sections below, which represent a particular location of the channel of the San Juan River in Utah. Changes in river discharge (Q), in cubic meters per second, and sediment deposits before, during, and after a flood are shown.

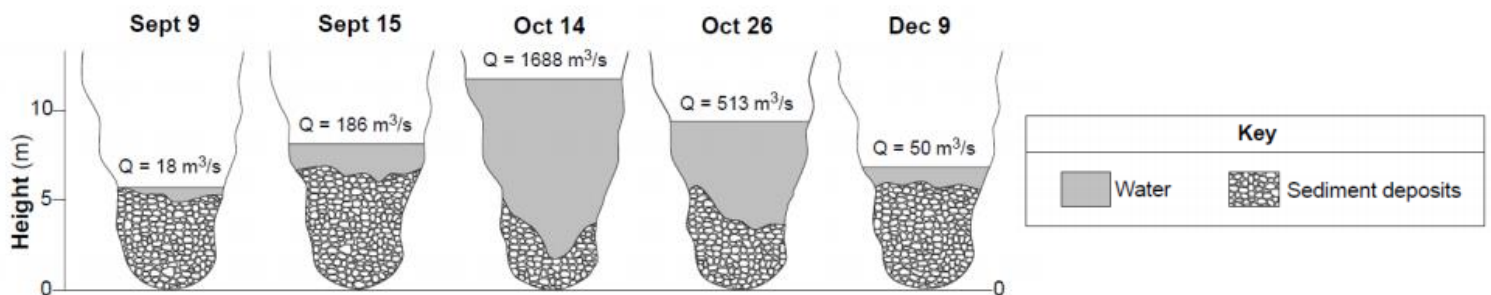

1. During the time from September 9 to October 14, the thickness of the sediment deposits at the bottom Of the San Juan River's channel
 - a. decreased, only
 - b. increased, only
 - c. decreased and then increased
 - d. increased and then decreased

PRACTICE PACKET: TOPIC 5 Surface Processes & Landscapes: Water & Ground

2. On October 14, during the flood, the discharge (_____) of the San Juan River changed dramatically. The change in the river's discharge at this location was related to an increase in the river's
 - a. velocity
 - b. gradient
 - c. channel length
 - d. sediment deposits

3. A river's current carries sediments into the ocean. Which sediment size will most likely be deposited in deeper water farthest from the shore?
 - a. pebble
 - b. sand
 - c. silt
 - d. clay

Base your answers to questions 4 and 5 on the diagram and data table below. The diagram shows the equipment used to determine the factors affecting the rate of erosion in a stream. The data table shows the time it took a 10-gram sample of quartz sand to move 100 centimeters down the rain gutter under various conditions.

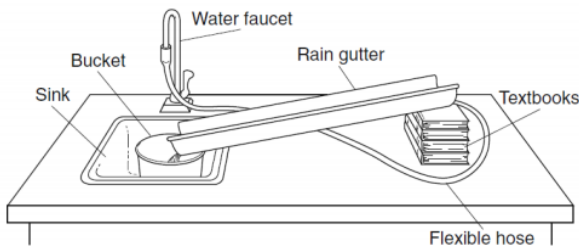

Data Table

Rain Gutter Slope	Water Velocity	Erosion Time (s)	
		Fine Sand	Coarse Sand
5°	slow	20	60
	fast	15	40
10°	slow	15	40
	fast	10	30
20°	slow	10	30
	fast	5	15

4. In this experiment, the water velocity could be increased by
 - a. decreasing the slope of the rain gutter
 - b. increasing the amount of water from the faucet
 - c. lowering the flexible hose
 - d. widening the rain gutter

5. What is the relationship between the water velocity and the rate of erosion?
 - a. If the water velocity decreases, the rate of erosion increases.
 - b. If the water velocity increases, the rate of erosion increases.
 - c. If the water velocity remains constant, the rate of erosion decreases.
 - d. If the water velocity remains constant, the rate of erosion increases.

6. On Earth's surface, transported materials are more common than residual materials. This condition is mainly the result of
 - a. Recrystallization
 - b. erosion
 - c. folding
 - d. subduction

7. By which processes are rocks broken up & moved to different locations?
 - a. Evaporation & condensation
 - b. Weathering & erosion
 - c. burial & cementation
 - d. compaction & transportation

8. The best evidence that erosion has taken place would be provided by
 - a. deep residual soil observed on a hill side
 - b. sediment observed at the bottom of a cliff
 - c. tilted rock layers observed on a mountain
 - d. faulted rock layers observed on a plateau

9. Which erosional force acts alone to produce avalanches and landslides?
 - a. gravity
 - b. running water
 - c. winds
 - d. sea waves

PRACTICE PACKET: TOPIC 5 Surface Processes & Landscapes: Water & Ground

10. At which point would erosion most likely be greatest?

- a. A b. B c. C d. F

11. When the velocity of a stream suddenly decreases, the sediment being transported undergoes an increase in

- a. Particle density c. Erosion
b. Deposition d. Mass movement

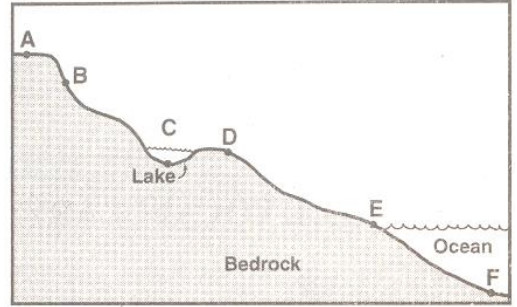

ASSESS YOURSELF ON THIS LESSON: _____/11

If you missed more than 3, do the additional practice. If not, go on to the next hw video!!!

1. Particles of soil often differ greatly from the underlying bedrock in color, mineral composition, and organic content. Which conclusion about these soil particles is best made from this evidence?

a. They are transported sediments. c. They are residual-sediments.
b. They are soluble in water. d. They are uniformly large-grained.

2. As the gradient of a stream increases, the stream's ability to carry sediment

a. decreases b. increases c. remains the same

3. Which is the best evidence that erosion has occurred?

a. a large number of fossils embedded in limestone
b. a soil rich in lime on top of a limestone bedrock
c. sediments found in a sandbar of a river
d. a layer of basalt found on the floor of the ocean

4. The map shows the elevation field for a 30-by-50-meter section of a parking lot on which a large pile of sand has been dumped. The isolines show the height of the sand above the surface of the parking lot in meters.

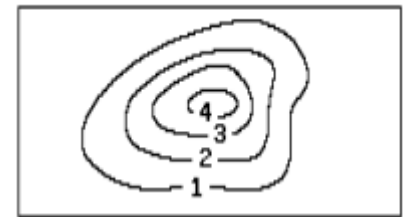

Which map represents the most likely elevation field for the same area after several heavy rainstorms?

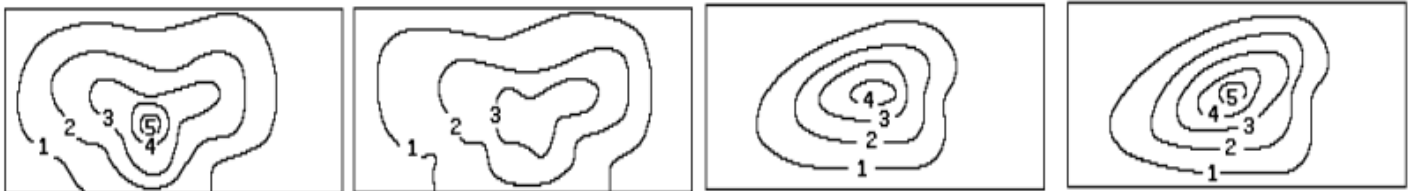

5. Which graph shows the relationship between the density of particles and their settling time in still water? [Assume that the particles have the same size and shape.]

